

INSTRUCTIONS

Frigimat® Cub - Dry Ice Maker - CATALOG NUMBER F38874-0000

SAFETY FIRST: Please read this entire instruction sheet before using this product to ensure maximum performance and safety.

Recommended Safety Equipment



Safety glasses



Gloves

Recommended Safety Equipment

WARNING

WARNING: because of the pressures and temperatures involved when working with liquid and/or solid carbon dioxide (CO₂), always wear safety glasses and insulated gloves. Do not tamper with the relief valve that extends from the brass fitting, (relief valve set at 12 psi). Return the unit to the factory for any repairs. NOTE: The pressure gauge may be swiveled in any convenient direction. Looseness of the gauge mounting is normal and will not cause a leak.

INTRODUCTION

The body of the FRIGIMAT® Cub - Dry Ice Maker is molded of polycarbonate plastic. Many chemicals and their vapors may attack the polycarbonate plastic and cause crazing (hairline cracks) which weakens the product and may result in explosion under pressure. Inspect the product for any cracking or damage before each use. Clean only with mild detergent and water and then air dry.

The bottom half of the FRIGIMAT® Cub - Dry Ice Maker includes a neoprene safety strap with attached lanyard. This strap must be used to secure the top and bottom halves together to produce a dry ice block. The Neoprene strap should be regularly checked for damage or cracks and replaced only with the Bel-Art Products specified strap.

NOTE: When ordering cylinders of CO₂ from your supplier, specify cylinders equipped with a dip tube. These cylinders can be used in an upright position. If the cylinder does not have a dip tube, lay the cylinder on its side with the valve lower than the cylinder.

INSTRUCTIONS

To Assemble:

1. One end of the "pig tail" (long metal tubing with fittings on either end), supplied should be attached to the threaded end of the brass fitting assembly and the other end threaded onto the cylinder control valve of the Liquid Carbon Dioxide (LCO₂) cylinder with dip tube.
2. Place the bottom half of the dry ice maker body on a flat surface, (attached to the bottom half is the neoprene strap with lanyard). With the pressure gauge extending upward and the fitting with pigtail pointing outward, place the entire brass fitting assembly into its holding bracket on the bottom half of the dry ice maker body. Ensure that fitting with O-ring seal is seated properly in groove in the dry ice maker body.
3. Place the top half of the body onto the bottom half engaging and trapping the brass fitting with O-ring seal.
4. Hold the assembled body down on a firm surface and pull upward on the lanyard to stretch the Neoprene strap up and over the top half of the dry ice maker body and down the opposite side to hook the Neoprene strap onto the cleat on the bottom half. Be sure the Neoprene strap is completely held by and centered on the cleat.
5. Stretch the Neoprene strap into the molded-in slots across each side of the top half of the dry ice maker body.

To Operate:

Attention: Do not operate the FRIGIMAT® Cub - Dry Ice Maker unattended

6. Open the cylinder valve very slightly to start the LCO₂ flow. Maintain the pressure at or below 1 psi (ONE psi) above the resting pressure on the outer scale of the gauge. It is normal to see some CO₂ vapors leaking from the seams and hear the sound of the CO₂ flowing. The transparent body of the unit allows viewing of the CO₂ forming into ice and filling the chamber. The dry ice block is fully formed when the pressure reading on the gauge rises rapidly and the sound of the gas flow becomes louder. Close the cylinder valve. The time to make each ice block will be approximately 4 – 5 minutes.
7. To remove the dry ice from the dry ice maker, release the Neoprene strap from the cleat and allow it to retract. Remove the top half of the body to expose the dry ice block. Remove the brass fitting with pigtail assembly. Invert the bottom half of the body to release the dry ice block.
8. The weight of dry ice block will be approximately 250 to 300 grams.
9. If making a second block ensure that any frost build-up does not prevent closure of the unit. Allow time for frost or ice to dissipate from the brass fitting and body of the FRIGIMAT® Cub - Dry Ice Maker.

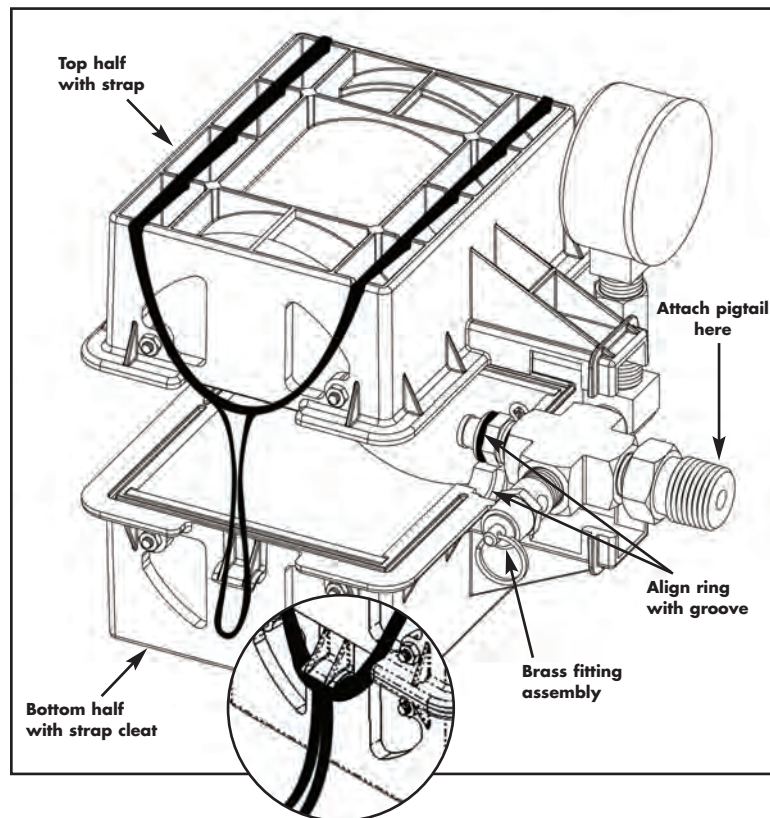

BEL-ART PRODUCTS

661 Route 23 South, Wayne, NJ 07470-6814 USA • TEL: 1-800-4BEL-ART • FAX: 973-694-7199 • www.belart.com

938874014

Scienceware®, Frigimat® are reg. TM of Bel-Art Products

Bel-Art Products assumes no obligation or liability for any advice furnished by it, or for results obtained with respect to these products. All such advice is given and accepted at the buyer's risk.

02/05

DID YOU KNOW?

PRINCIPLES OF OPERATION:

The Frigimat® Cub - Dry Ice Maker utilizes the Joule-Thomson effect to produce solid CO₂ from liquid CO₂. The CO₂ enters the cavity through an orifice and vaporizes at essentially atmospheric pressure. The chamber is cooled by the vaporizing CO₂. The result is a progressive chilling of both the incoming CO₂ and the dry ice maker until a temperature is reached at which the incoming CO₂ is directly converted to hard-packed carbon dioxide snow. As more CO₂ is frozen, the snow is compressed inside the chamber to produce the solid dry ice cake.

VARIATIONS OF LIQUID CONTENT IN CO₂:

When CO₂ cylinders are filled with gas, the cylinder pressure is maintained at between 700 and 850 psi. Under this pressure, approximately 30 percent of the cylinder volume is filled with gas while the remainder contains liquid.

The Frigimat® Cub - Dry Ice Maker will produce dry ice only from liquid CO₂. The amount of dry ice which can be made is a function of the amount of liquid present in the cylinder. This in turn, is a function of the temperature of the cylinder.

A cooler cylinder contains more liquid and thus can produce more dry ice. As the following chart indicates at 60°F (15.6°C) approximately 77% by weight of the CO₂ is liquid. At 70°F (21°C) liquid content has decreased to 70%, while at 80°F (26.7°C) it is only 58%. If the temperature of the cylinder is above 88°F (31°C), the critical temperature, only gas is present and dry ice cannot be made.

CYLINDER AT VARIOUS TEMPERATURES

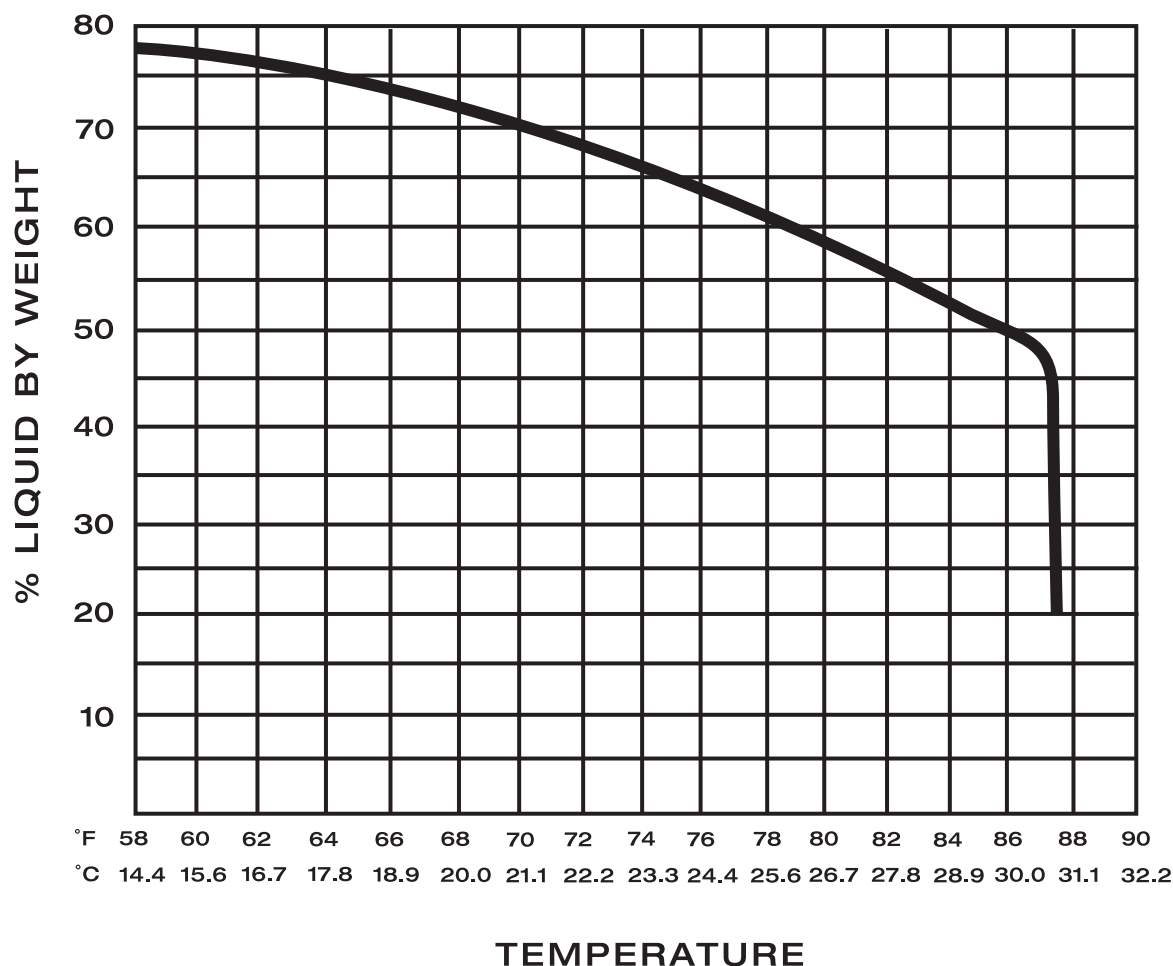

BEL-ART PRODUCTS